



*Engineered
for Accuracy
and Simple
Installation*

VANTAGE 4000
Ultrasonic Transit-Time Flowmeter

 EASTTECH

VANTAGE 4000

TRANSIT-TIME FLOWMETER

Model 4400

- ▶ One 4-20 mA Output
- ▶ One SPDT Relay
- ▶ RS232 Serial Port (Modbus RTU Protocol)
- ▶ Internal Datalogger

Model 4600

- ▶ Two 4-20 mA Outputs
- ▶ Three SPDT Relays
- ▶ RS232 Serial Port (Modbus RTU Protocol)
- ▶ RS485 Serial Port (Modbus RTU Protocol)
- ▶ Internal Datalogger

FACTORY PRE-PROGRAMMED

The engineers at Eastech realized that for a new product to be successful, it must be simple to install and quickly made operational. In order to accomplish this goal, every

PROGRAMMING VALIDATION

PIPE SIZE: 16 IN.
PIPE MATERIAL: DUCTILE
FLOW MEDIA: WATER
MAX PRESSURE: 100 PSI
FLOW DIRECTION: UNI-DIR

Vantage 4000 is shipped to the field factory pre-programmed to the conditions set forth by the customer. Pre-programming specifications are electronically

confirmed on the display of the transmitter. If changes to the meter's factory pre-programming is required, re-programming can simply be accomplished on the meter keypad or through the **Auto-Programming** feature. This feature allows plant personnel to re-program the Vantage 4000 by simply downloading the revised flow data from a PC or laptop directly into the meter.

Accuracy & Reliability

The Vantage® 4000 employs the latest DSP microprocessor technology. An exclusive signal processing technique combines correlation and FFT detection methods in order to ensure the highest degree of accuracy and reliability possible.

Turndown: 400:1

Repeatability: 0.25%

Accuracy: ±1% of actual flow



SPEEDRAIL™ SENSOR MOUNTING

Since the externally mounted sensor is the preferred design for transmitting signals through pipe or conduit, a new one-piece *SpeedRail™* sensor mounting system was developed. Mounting of both sensors is quickly and accurately accomplished in two simple steps. Lock the self-aligning mounting rail to the pipe or conduit and load in the sensors. **Once the sensors are connected to the transmitter, the Vantage 4000 is ready to measure flow.**

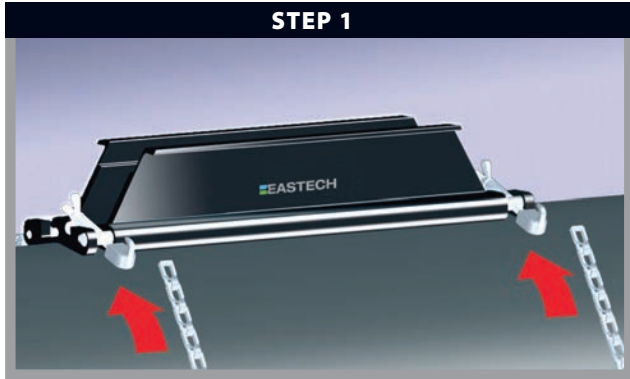

FLOW DATA GRAPHING PACKAGE

QTrend 2007 is an Excel Workbook Flow Data Graphing Package specifically designed to interface with every meter offered within the Eastech product line.

QTrend incorporates specific formulas capable of automating the process of charting and displaying all data contained within the onboard logger of the meter. Each individual Worksheet presents an OPEN FILE button. Upon initiation, the file browser is displayed with a complete list of all CSV files contained within the directory. Choosing a file of interest will automatically import the data from that file into the QTrend Excel Workbook. By simply clicking on the tab labeled CHART, a comprehensive flow evaluation and trend analysis Worksheet is displayed.

All graphed data is presented in a color-coded format that coincides with a complete set of corresponding Data Description Keys prominently displayed on the left perimeter of the Worksheet. For specific analysis, associated data may be temporarily hidden from view by a simple click on the appropriate Data Description Key. Maximum and minimum values for every measurement category are updated and then displayed within each graphical window.

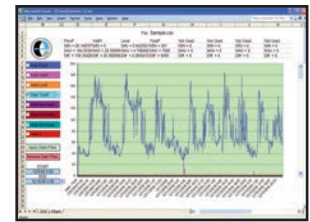
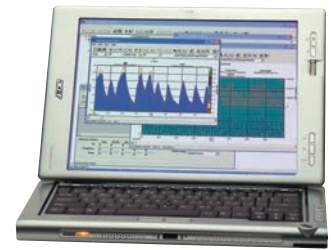

Flow and Level (Total Flow Hidden)

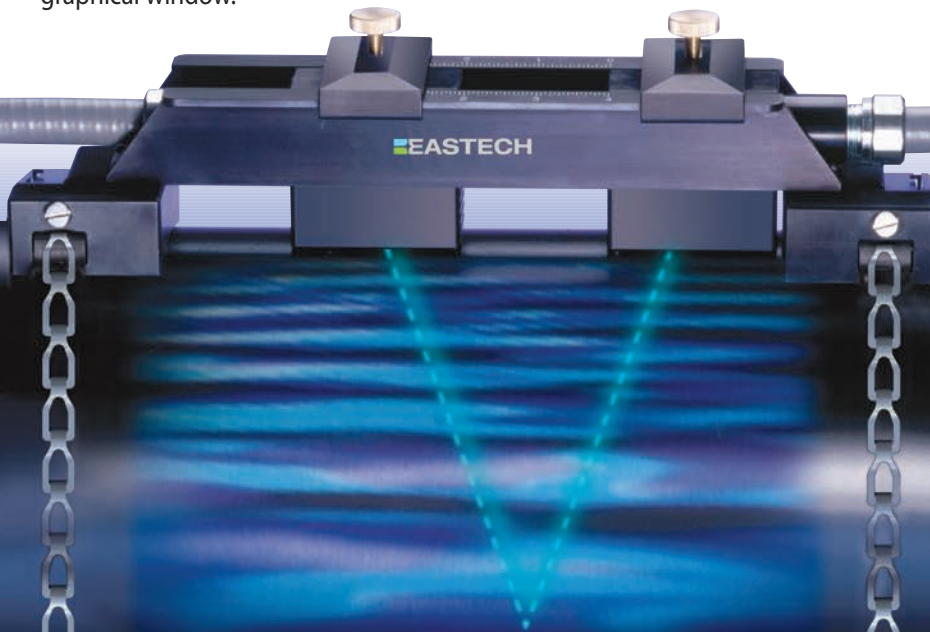

TRANSMITTER



- ▶ Water & Wastewater
- ▶ Sewage Treatment
- ▶ Acids & Toxic Liquids
- ▶ Petroleum Products
- ▶ HVAC & Irrigation

Eastech was the first company to utilize a phase shift detection system in the design of transit-time flowmeters. This technique greatly improves time difference detectability, which in turn, enhances accuracy and operating stability while substantially reducing the effects of noise.

ACCURACY & RELIABILITY

- Turndown: 400:1**
- Repeatability: 0.25%**
- Accuracy: ±1% of actual flow**

The electronic design of the Vantage 4000 utilizes the latest microprocessor technology and operates in conjunction with a DSP floating point coprocessor. An exclusive signal processing technique combines correlation and FFT detection methods to ensure the highest degree of accuracy and reliability.

Flash memory is employed for logging of flow data. Up to 8 channels can be logged—including flow, velocity and totals for one or multiple sensors. The storage capacity for a single channel logging at 5 minute intervals is 113 days. In addition, graphs may be visually displayed in pre-programmed time intervals. Daily summary allows viewing of the previous eight days. This includes times, dates, averages, minimums, maximums and totals. Plant operating personnel also have the ability to simply download logger data through the use of a standard laptop.

PROGRAMMING

For fast and simple installation, each Vantage Series 4000 is pre-programmed at the factory for customer specific flow measurement applications.

If re-programming is required in the field, the **Auto-Programming** feature allows for the corrected flow data to simply be downloaded from a PC or laptop directly into the meter. Additionally, a self-prompting backlit display, with a menu-driven guide allows for 15 minute programming of standard applications and 30 minute programming of in-depth data logging applications and auxiliary outputs.

Programming of the meter is accomplished through the 16 button keypad. The LCD display is a backlit 128 x 64 graphic module. A simple to use drill-down menu structure allows for quick programming and set-up of the meter. Most common pipe sizes and schedules are stored in memory for ease in programming a specific application. Non-volatile memory ensures that programming constants are not lost during disruption of power.

Model 4400	Model 4600
<ul style="list-style-type: none"> ▶ One 4-20 mA Output ▶ One SPDT Relay ▶ RS232 Serial Port (Modbus RTU Protocol) ▶ Internal Datalogger 	<ul style="list-style-type: none"> ▶ Two 4-20 mA Outputs ▶ Three SPDT Relays ▶ RS232 Serial Port (Modbus RTU Protocol) ▶ RS485 Serial Port (Modbus RTU Protocol) ▶ Internal Datalogger

DATA LOGGING

The Vantage 4000 has a 256K Byte logger with storage intervals. The logger can be programmed for various time intervals. Up to 8 channels can be logged—including flow, velocity and totals for one or multiple sensors. The storage capacity for a single channel @ 5 minute intervals is 113 days. IEEE floating point storage is used.

Daily Averages

Flash memory is employed for logging of flow data. Data is retrieved by viewing the local display or downloaded via the serial port. Daily summaries allow viewing of the previous eight days. Included are times, dates, averages, minimums, maximums and totals.

Logger Graph

A graph may be visually displayed on the 4000. The graph will display the stored logger data in pre-programmed time intervals.

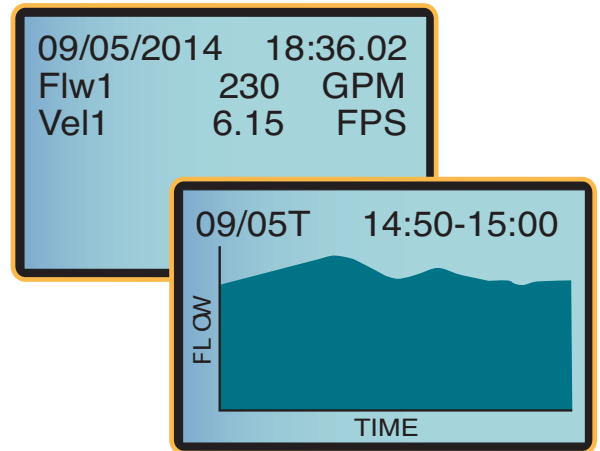

DATA RETRIEVAL

The Vantage 4000 is designed for reliable and accurate retrieval of data—either on-site or remotely. The unit is equipped, as standard, with an integrated data logger capable of storing large amounts of information for later analysis. Because of its multiple output capability, this information may simply be retrieved through the use of one of the following methods.

Multiple Outputs

- Two 4-20 mA** Isolated, 800 ohms maximum.
- Three SPDT Relays** Available for alarm conditions.
- RS232** With Modbus protocol. Flow control is CTS/RTS or none. DB-9 connection.
- RS485** With Modbus protocol, isolated. The RS-232 & RS-485 can be set with different slave I.D.s.

INTEGRATED CHART RECORDER

A SINGLE NEMA 4, 4X UNIT INCORPORATING A CHART RECORDER, FLOWMETER AND DATALOGGER

- ▶ Fully Integrated Package
- ▶ Powered by Flowmeter
- ▶ User Selectable Output Ranges and Recording Times



Accuracy	.05% Full Scale
Power Source	100/240 VAC, 50/60 Hz
	12-28 VDC @ 300 mA
Channels	One
Recorder Display	112 x 16 Graphical
Chart Rotation	User Selectable
Chart Range	0 - 100% of Full Scale
Chart Size:	100 mm Diameter

Recording Time	24 Hour, 7 day, 31 day (user selectable)
Response Time	4 sec. - 60 sec. (user selectable)
Calibration	Pen Arm
Relays	3 SPDT (plug-in) 3 Amps
Chart Replacement Alarm	Flashing LED (Red)
Environmental protection	Nema 4, 4X
Temperature	Standard: -4° to 158°F (-20° to 70°C)
	With Heater: -40° to 158°F (-40° to 70°C)

ACOUSTIC SENSORS



The externally mounted sensor is the preferred design when acoustic signals are capable of being transmitted through pipe or conduit.

Eastech offers a wide range of sensor options covering a multitude of applications. Simple “walk through” installation instructions are graphically displayed in the IOM for local reference in the field

EXTERNALLY MOUNTED SENSOR

Externally mounted sensors are the preferred design when acoustic signals are capable of being transmitted through pipe or conduit. The sensors are fully potted for use in highly corrosive areas. Both sensors and mounting hardware are designed to resist corrosion, function when buried or submerged and operate over a wide temperature range of -30° to 150°F (-30° to 300°F optional). External sensors are suitable for placement on all metallic and plastic piping, with the exception of pit cast iron and layered fiberglass pipe.

Application: 1” and larger. Plastic, Metallic, Asbestos Cement and Ductile/Cast Pipe.

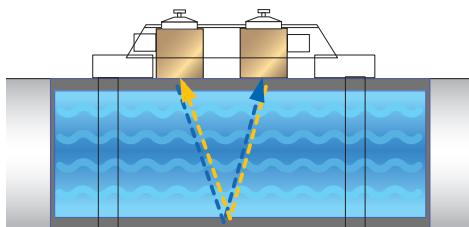

Externally mounted non-wetted sensors (V-Shot)

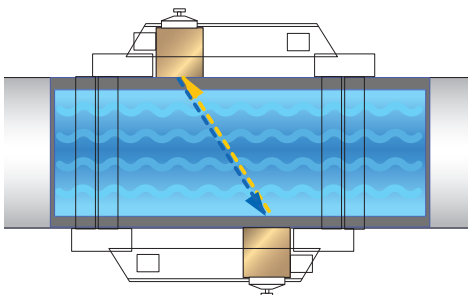

Externally mounted non-wetted sensors (Z-Shot)

SPEEDRAIL MOUNTING

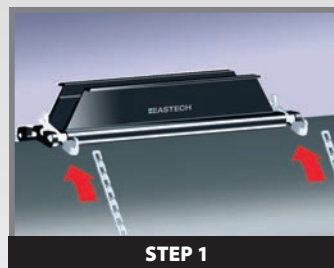

Since externally mounted sensors are the preferred design for transmitting signals through pipe or conduit, a new one piece **SpeedRail™** sensor mounting system was developed. Mounting of both sensors is quickly and accurately accomplished in two simple steps. Lock the self-aligning mounting rail to the pipe or conduit and load in the sensors.

Once the sensors are connected to the transmitter, the Vantage 4000 is ready to measure flow.

INSTREAM SENSOR

In open conduits over 12 inches in width or in large concrete pipes where the outside of the pipe is not accessible, the instream sensor is recommended for accurate fluid velocity measurement. The design of the sensor facilitates simple installation. Sensor configuration allows flush mounting against the sidewall. For accuracy and ease of installation, a unique internal hoop design is available with premounted instream sensors. This mounting arrangement makes installation fast and precise. Sensors are constructed of PVC and are fully potted.

Application: Large diameter pipe and pipe or conduit not accessible from the outside.

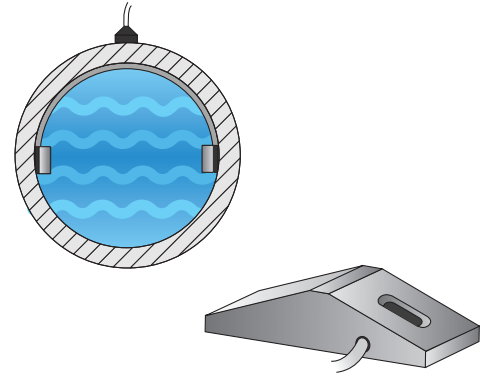

WINDOWED SENSOR

Fabricated spool pieces are available in a windowed sensor design with a wide choice of end connections and materials of construction. Spool pieces are supplied with both sensors mounted and calibrated to the electronics. Windowed sensors transmit and receive ultrasonic pulses through an acoustic window which is in contact with the flow stream. The design allows sensor removal without de-watering of the line. The sensors and windows are constructed of Ultem® thermoplastic material and carry a temperature rating of 150°F and a pressure rating of 150 psi.

Application: 3" to 48" with stainless or carbon steel construction and ANSI, AWWA and plain end connections.

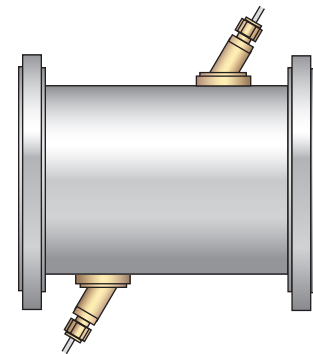

HOT SHOT SENSOR

"Hot Shot" sensors are utilized on piping or conduits that inhibit the transmission of acoustic energy. A standard concrete saddle tap is employed for penetration of the pipe wall. "Hot Shot" sensors are available for 12" and larger pipe. The sensor design allows for flush mounting within the conduit, thereby eliminating turbulence or the build-up of solids around the measuring point. Sensors are provided with an integral valve in order to allow sensor removal without shutting the process down. Constructed of PVC and fully potted, the sensors carry a pressure rating of 150 psi.

Application: Concrete, Asbestos, Cement, Fiberglass Wrapped, Wood Stave, heavily corroded steel pipe and pipes with considerable calcium build-up.

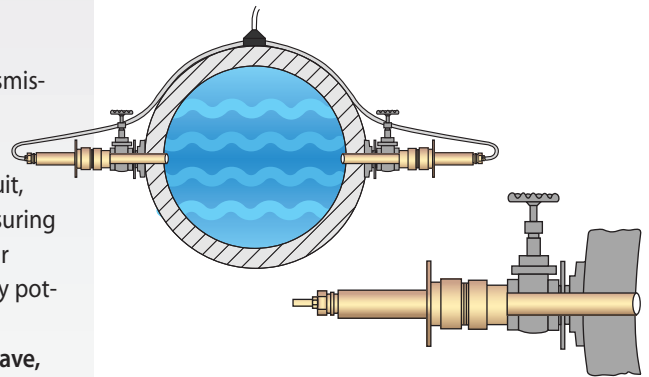

MULTI-PATH

Two and three path diametrical sensor configurations are recommended for applications that do not have normal upstream straight runs to produce well developed velocity profiles. The average axial velocity component for each acoustic path is utilized to establish the velocity profile. The velocity profile is then numerically integrated over the conduit's cross-sectional area to determine the volumetric flow rate. As a result, flowmeter accuracy is relatively independent of the velocity profile.

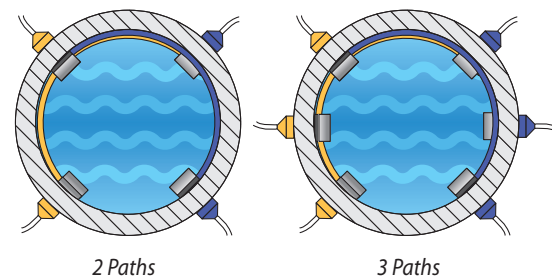

SPECIFICATIONS

PERFORMANCE

Linearity	± 0.25%
Repeatability	0.25%
Accuracy	±0.5% of actual flow
Turndown	400 : 1
Power Supply	High immunity: Approvals CE, UL, CSA
Input Range	100 to 240 VAC
Input Freq. Range	50 to 60 Hz

SENSORS

Pipe Diameter	1" to 120" (above 120", consult factory)	
Temperature Rating	-30° to 150° F Optional to 300° F (Clamp-on only)	
Sensor	Pressure Rating	Max. Cable Distance
Clamp-on (1" - 300")	Not applicable	1000 ft.
Instream (12" - 120")	150 PSI	1000 ft.
Wetted (12" - 120")	150 PSI	1000 ft.
Windowed (3" - 48")	250 PSI	250 ft.
Materials of Construction		
Sensors:	Anod. Alum./Ultem®/PVC	
Clamp-on hardware	Anod. Alum.	
Hot-Shot Valve Body	Brass	
Sensor Cable	Triax Beldon 9222 (50 ft. std.)	

TRANSMITTER

ENCLOSURE	
Standard	Nema, 4, 4X polycarbonate (9.25" x 8.87" x 5.38")
Accessories	Heater and thermostat, Door Lock, Modem
TEMPERATURE	
Standard	-4° to 158°F (-20 to 70°C)
With Heater	-40° to 158°F (-40 to 70°C)
OUTPUTS	
4-20 mA	Analog isolated into 800 ohms max, monitored to detect open circuits. RFI and gas discharge surge protection and two fuses.
Relay Alarms	SPDT relays (pluggable) 3.0A @ 120VAC / 24VDC
RS-232 Serial Port	1200-38400 Baud, Modbus RTU protocol
RS-485 Serial Port	Optically isolated, Modbus RTU protocol
DC Power Out	12 VDC, 100mA maximum
DISPLAY	
Backlit LCD	128 x 64 Graphic Module
POWER	
Wattage	12
Voltage	100/240 VAC, 50/60 Hz / 12-28VDC @ 300 mA.
DATA LOGGING	
Non-volatile flash memory, storage of up to 32768 records.	

ORDERING GUIDE (Please specify pipe size, pipe material, flow media and flow direction)

Enclosure	Sensors	Extra Cable	Options	Data Retrieval
4400 (Uni-directional) Nema 4, 4x; General Purpose • One 4-20mA output • One SPDT Relay • RS-232 serial port	External Clamp-On (1" - 42" Dia. Pipe) AS1 External Clamp-On (48" - 120" Dia. Pipe) AS2 External Clamp-On (High Temp.: 300°F) AS3 Instream (12" - 120" Dia. Pipe) AS4 Wetted "Hot Shot" (12" - 120" Dia. Pipe) AS5 Windowed (3" - 48" Dia. Pipe) AS6 Multi-Path contact factory.	Note: Each sensor is equipped with 50 feet of cable as standard. 100 ft. B Above 100 ft. Please specify exact cable length. ft.	Factory Calibrated A (No Charge) Heater & Thermostat B Keylock C Splice Kit D Extra Relays (Model 4400) 2 Relays E 3 Relays F	Modem (phone line) M
4600 (Bi-directional) Nema 4, 4x; General Purpose • Two 4-20mA outputs • 3 SPDT Relays • RS-232 serial port • RS-485 serial port • Internal Datalogger For Div. 1 Explosionproof areas contact factory.				
CHART RECORDER 15 Nema 4, 4X • IP66 Circular Chart (please specify) 1 Day • 7 Day • 31 Day				